

Phototriac Application Note

Introduction

As is the case for TRIACs in general, phototriacs have traditionally been used as solid-state AC switches. As a matter of fact, in many industries such as industrial and process control, it is not uncommon to use the term Solid State Relay and phototriac synonymously.

Vishay has a wide range of phototriacs which span the gamut in terms of performance, features, and cost. Also, in addition to phototriacs, Vishay offers unidirectional AC switches in the form of the photo-SCRs. These are listed in Table 1.

	PART #	Trigger Current (mA)	Isolation Voltage	Peak ANODE Voltage	Total Power Dissipation at 25 °C
	H11C4	11 mA	5300 V _{RMS}	400 V	400 mW
	H11C5	11 mA		400 V	400 mW
	H11C6	14 mA		400 V	400 mW
	IL400	10 mA		400 V	250 mW
	4N39	14 mA		200V	450 mW

Table 1: PhotoSCRs

Vishay's phototriacs vary, in terms of break-down voltage, power rating, and a parameter which is most important when designing with phototriacs and TRIACs in general, dV/dt. Most of the applications for phototriacs involve their use as AC switches; however, they can also be used as simple DC latches in unique applications. The possibilities are only limited by the designers imagination.

Phototriacs and photoSCRs are used where electrical isolation is required from driving source to load. This isolation requirement can be driven by electrical safety as well as other requirements. These include, ground-loop mitigation, EMI mitigation, etc.. All Vishay couplers meet UL safety agency standards, and can meet VDE requirements when ordered with Option 1 (please refer to Vishay's Safety agency Guidelines application note). Vishay's selection of phototriacs is listed in Table 2.

Vishay Phototriac Selection Table

Device Number	Trigger current (mA)	Zero Crossing Switching	Isolation Voltage (V)	V _{drm} (V)	dV/dt	Total Power Dissipation at 25 °C (mW)
IL410	2	Yes	5300	600	10 kV/μs	500
IL4108	2	Yes		800		
IL4116-8	1.3	Yes		600 - 800		
IL420	2	No		600		
IL4208	2	No		800		
IL4216-8	1.3	No		600 - 800		
IL440-1	15	No		600	50 V/μs	300
IL440-2	10	No		600		
IL440-3	5	No		600		
IL440-4	15	No		400		
IL440-5	10	No		400		
IL440-6	5	No		400		
K3010P(G) Series	5 to 15	No		250	10 kV/μs	350
K3020P(G) Series	5 to 30	No		400	1.5 kV/μs	250
VO3052	10	No		600		
VO3053	5	No		600		
VO3062	10	Yes	600			
VO3063	5	Yes	600			
VO4157	1.6 to 3	Yes	700	5 kV/μs		
VO4158	1.6 to 3	Yes	800			
VO4257	1.6 to 3	No	700			
VO4258	1.6 to 3	No	800			

Table 2: Phototriacs selection guide

Input (Emitter Side)

Vishay's phototriacs are driven by a GaAs LED, which in turn generates optical energy that is collected by a photoSCR. As is the case for standard Optocoupler products, it is important to perform a worst case analysis, when determining the optimum driving current. This will allow the designer to choose the correct I_{FT} under worst case temperature, and component variance conditions.

The first thing to determine is the required turn-on time for the switch in question. The faster the desired turn-on time, the more current is required to turn on the device. This is intuitive for those used to working with MOS devices such as Solid State Relays, which likewise require increased LED current with increasingly faster turn-on times. Figure 1 is an excellent graphical presentation of this parametric trend. It clearly demonstrates two important trends, trigger delay increases with increasing temperature and decreasing I_{FT} .

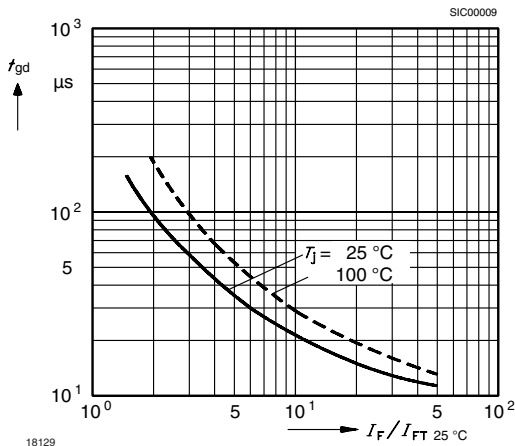

Figure 1.

In addition to the affects of temperature and switching time, one needs to take into account the power dissipated in the Optocoupler as a whole and the LED in particular. Vishay data sheets document limits for both. When attempting to calculate the maximum permissible LED current, it is important to accurately establish the forward voltage drop across the LED. This is well illustrated in Figure 2, with Figure 3 providing the maximum allowable power dissipation at various ambient temperatures.

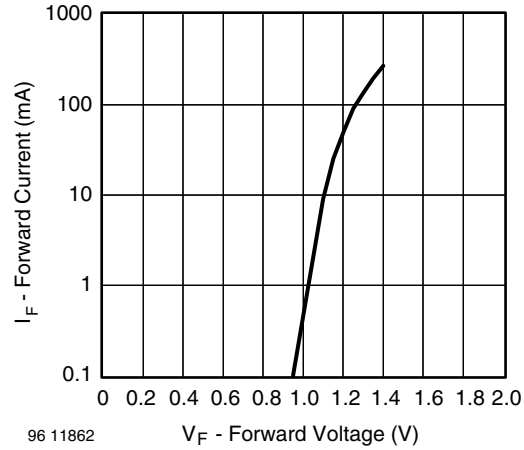

Figure 2.

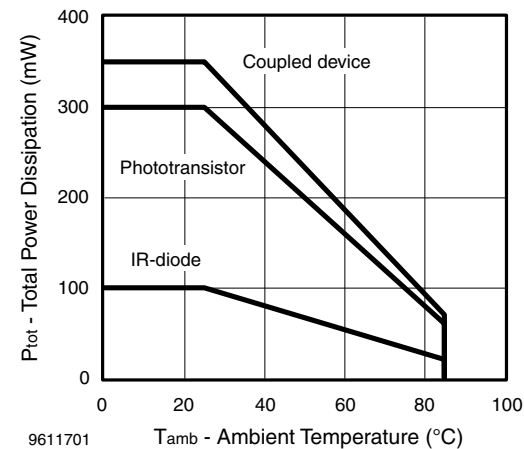

Figure 3.

Finally, when discussing LED drive design it is important to take into account one last consideration, LED "aging". This is a well known phenomena, but unfortunately one that is highly exaggerated and not well understood. It is true that GaAs LEDs degrade over time; however, the amount of degradation is usually not something that limits the performance of most end-products given normal operating conditions and equipment life cycles.

The parameters that affect LED aging are temperature, and LED drive current. As the temperature and LED current increases the aging process of the LED increases. This process is only significant under the most extreme examples of temperature and current. Under most conditions, it can be expected that the optocoupler will outlast the expected operational life of most products.

Output (Detector Side)

A TRIAC is a subset of a family of semiconductors referred to as thyristors. These are all four-layer bipolar devices with various triggering configurations. Regardless of the specific flavor of thyristor used, they all are built on the basic thyristor structure illustrated below in Figure 4-a.

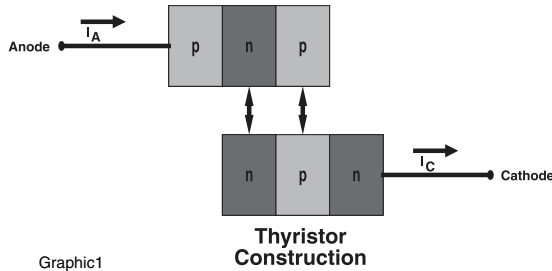

Figure 4-a.

Figure 4-b is the IV curve most commonly associated with thyristor components. Note that the curve of a thyristor is actually quite similar to the characteristic curve of a standard diode, with the notable exception that the current increases slowly with voltage until a maximum point—commonly referred to as the “snap-back” voltage—is reached. Having reached this point, the voltage across the thyristor drops sharply and the current begins to increase in a highly exponential function, as would be expected in a standard diode. Figure 4-b illustrates this behavior using a “typical” IV curve for a classic silicon controlled rectifier (SCR).

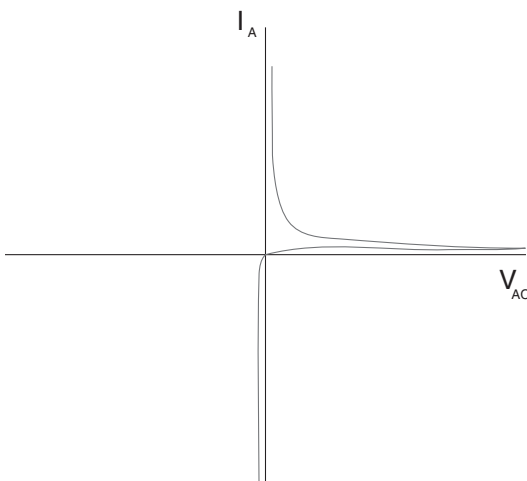

Figure 4-b. Typical SCR Curve

The functionality of a thyristor is most easily understood if one thinks of the device as two bipolar transistors where the collector of one transistor drives the

base of the other, as illustrated in Figure 4-c. Thus, when this device is turned on it will remain on until the current through the device drops to zero. This is a simplified view of TRIAC performance, however, and ignores some second-order effects that are key to successful TRIAC designs.

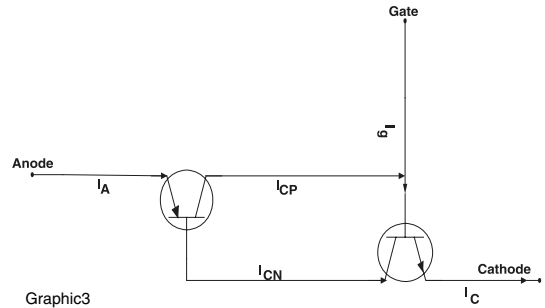

Figure 4-c.

A thyristor can be triggered by applying a voltage across its output terminals of sufficient amplitude to exceed its breakdown or snapback voltage. This type of triggering method is quite common and is used in thyristor devices referred to as DIACs; however, conduction can also be achieved in a more controllable fashion by connecting a triggering gate that allows for the injection of minority carriers into the gate region. In this way, a TRIAC can be triggered in much the same way as a bipolar transistor. This type of thyristor configuration is known as an SCR (Silicon Controlled Rectifier). Its schematic symbol and internal construction are illustrated in Figure 5.

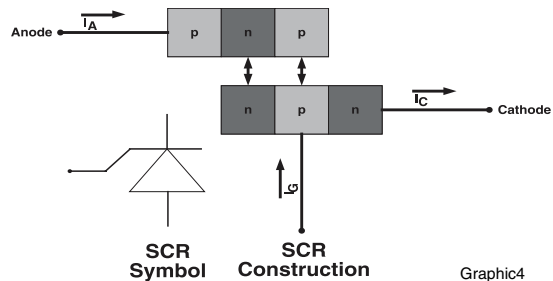
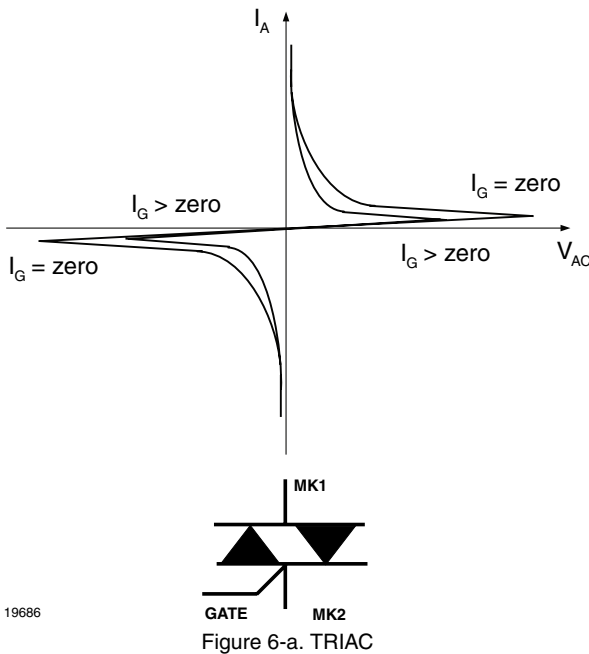

Figure 5.

Such devices act as unidirectional AC switch. Unidirectional, because current is allowed to flow in only one direction and AC switch, because it relies on the zero current crossing of the AC waveform to turn off the switch, once it has been triggered. The final config-

Vishay Semiconductors

uration that needs to be considered is the TRIAC, which is a bi-directional AC switch. If one understands the characteristics and functionality of an SCR, a TRIAC can be thought of as two back-to-back SCRs with a common gate. This structure allows current to flow in both polarities and thereby constitutes a highly effective AC switch. Figure 6-a illustrates the schematic symbol and the IV characteristic curves of a typical TRIAC. Note that the snapback voltage decreases as the gate current increases from an initial 0 point value.



19686

Figure 6-a. TRIAC

Finally, a phototriac can be implemented in two different ways, with the main differentiation being on the detector portion of the device. In one case the TRIAC itself can be designed such that it has a photosensitive gate region, in a way analogous to the base region of a phototransistor. This is the preferred detector configuration for inexpensive devices. Higher-performing devices employ a detector configuration similar to the one illustrated in Figure 6-b. This detector configuration does not employ a simple TRIAC with a photosensitive region; its more sophisticated and complex approach consists of a power stage made up of a TRIAC, or two SCRs driven by a driver stage, which is in turn triggered by a photosensitive device such as a photodiode or phototransistor. This approach has the advantage of giving the designer the flexibility of adding circuitry to the driver stage to increase parametric performance. Moreover, the physical separation of the power stage from the driver and trigger sections of the device has an inherent benefit in terms of noise immunity. The physical isolation of the separate stages of the device decreases coupling due to parasitic impedances between the output circuit and the drive and trigger circuitry.

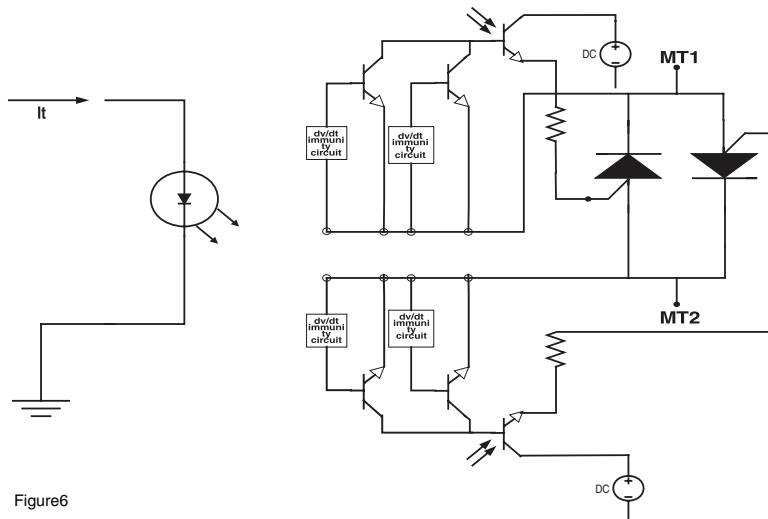

Figure6

Figure 6-b. Phototriac Functional Diagram

Types of Phototriacs

There are two different types of phototriacs available, non-zero crossing (NZC) and zero crossing (ZC) phototriacs. Each of which are suitable for different applications. Vishay offers both non-zero crossing and zero crossing phototriacs to be able to provide a solution for all different applications.

Non zero crossing Phototriac

The NZC phototriacs are used for the application that require fine control involving shorter time constants. Example of such application is light dimmers where coarse control would produce annoying flickering. Another example for NZC phototriac application is motor control where fine control would causes mooth and uninterrupted movements.

Use of NZC phototriacs, however, can produce very sharp di/dt transient across the TRIAC, with resulting detrimental outcomes.

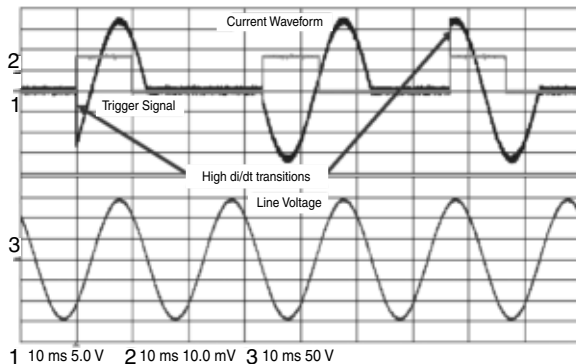

19687

Figure 7. NZC TRIAC Waveforms

Today, in most product designs, controlling the radio frequency interference (RFI) and electro magnetics compliance is of increasing concern. The sharp frequency generated by the sharp di/dt transitions make themselves known by radiating directly out into space as RFI and by operating down the power lines which turn also radiate the lower frequency harmonics that would not otherwise be radiated directly.

Zero crossing Phototriac

ZC phototriacs are limited to applications where the control time constant is significantly large. Such applications are heater control or solenoid drivers.

There are several advantages to use of the ZC phototriacs. Figure 8 is an example of ZC phototriac application.

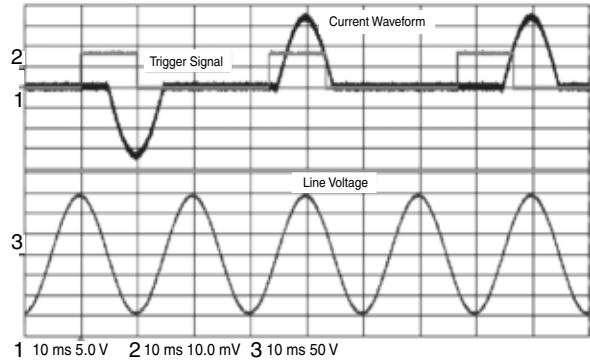

19689

Figure 8. ZC TRIAC Waveforms

As an example anyone that has ever dimmed their lights and seen “snow” on a television screen has witnessed the effects of RFI. The reduction of RFI is often the critical reason for using a ZC phototriac. It is a known fact that: any signal which is not a sinusoidal function is made up of a fundamental frequency and an infinite series of harmonics of decreasing amplitude. The higher the frequency of the harmonics generated, the easier it is to effectively propagate it into free space with an antenna of small dimensions. Hence, if you don't want to generate noise, make your waveforms as close to a sinusoidal waveforms as possible. Figure 9 graphically illustrates this point.

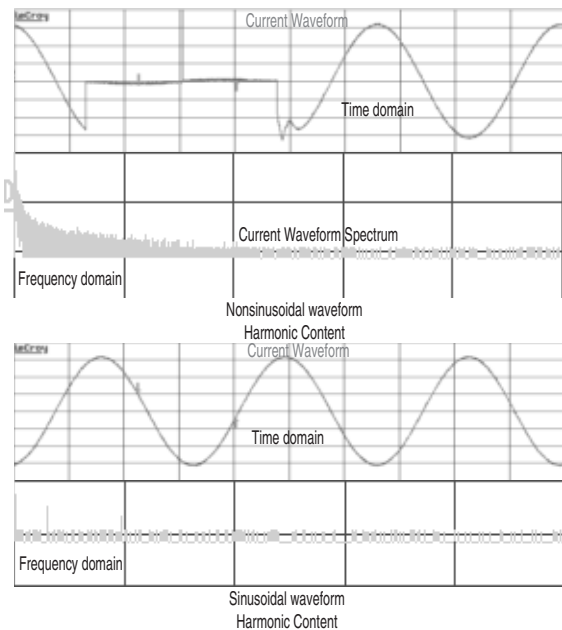

Graphic25_new

Figure 9. Harmonic Content of Non-Sinusoidal Current Waveforms

Another advantage of a zero-voltage triggering phototriac is the fact that since the trigger always occurs at the zero crossing point, it allows the maximum amount of time for current to build up across an inductive load. This is illustrated by the fundamental equation:

$$V = L di/dt$$

and the waveforms in Figure 10.

In Figure 10-a, a motor contactor was first triggered with a NZC TRIAC, with the result that there was not enough time for current to build up to a sufficient magnitude to activate the contactor armature. In Figure 10-b, current was given the full half cycle, thus resulting in a larger peak current build up, and thus contactor closure.

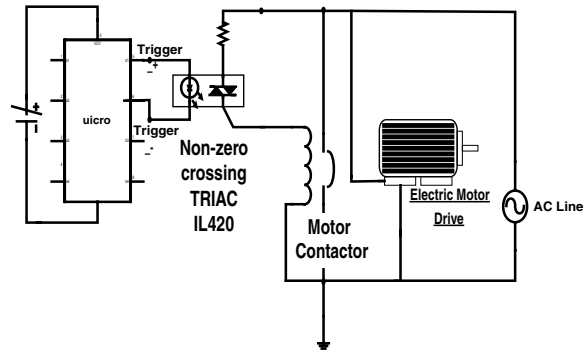
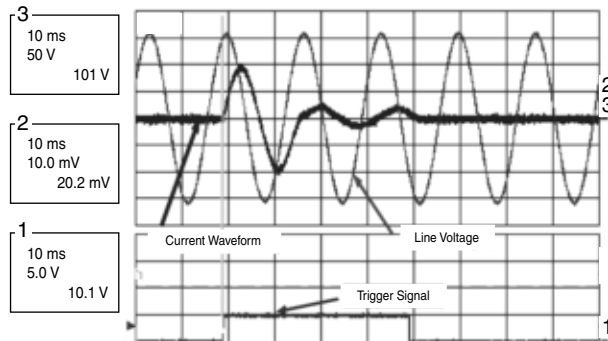

Figure 10-a. NZC TRIAC - Lower Peak I

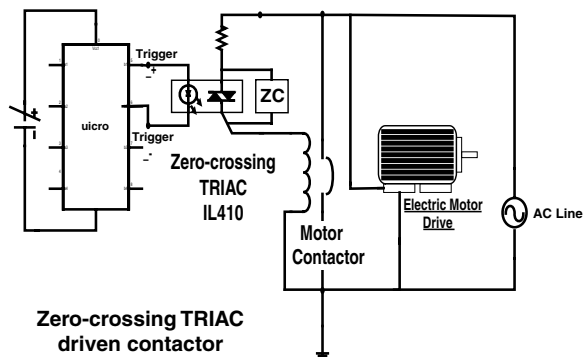
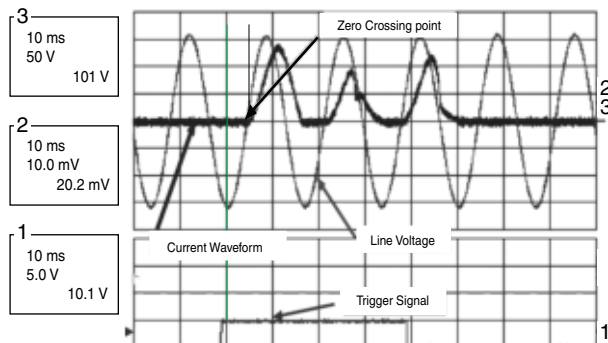

Figure 10-b. ZC TRIAC - Higher Peak I

Finally, it is true that a zero-crossing implementation does not necessarily mandate the use of a ZC phototriac. A zero-crossing detector can be implemented using various approaches ranging from IC comparators and op amp circuits to simple discrete devices. Yet, when one takes into account the increase in circuit complexity, added component cost, and the requirement for galvanic isolation between the TRIAC output and input driving LED, and the need to reduce board real estate, a ZC phototriac looks very attractive as illustrated in the two schematics of Figure 11.

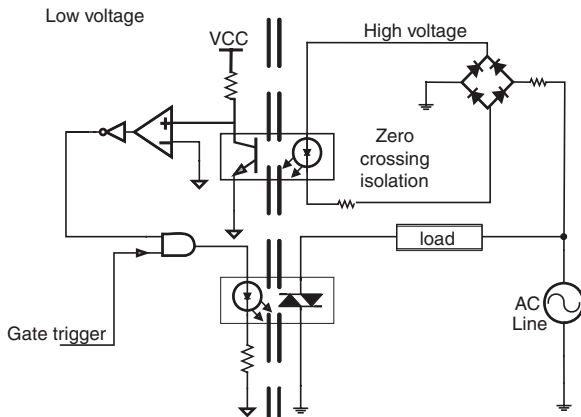

Figure 11-a. Discrete ZC Solution

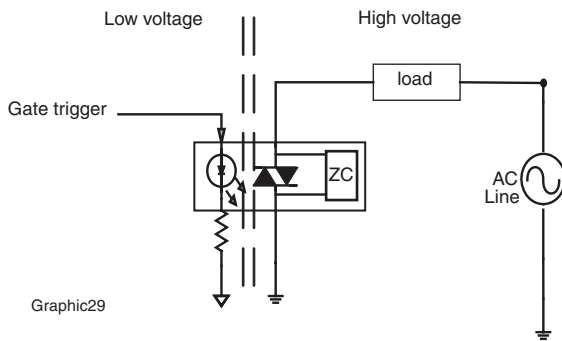

Figure 11-b. ZC TRIAC Solution

Phototriac As Static Switches

Thyristors have been around longer than any other type of power semiconductor, and for many years they ruled the domain of solid-state power switching exclusively. Today, with the advances in power MOSFET technology, TRIACs are sometimes replaced by MOSFETs. Yet when it comes to low-cost AC switching applications, TRIACs still have a very important role.

In many applications, TRIACs are used instead of a simple mechanical switches because of the following advantages:

1. Solid state reliability
2. Elimination of contact bounce
3. Elimination of contact arcing
4. Small size to current handling capacity

Figure 12 illustrates what is arguably the simplest TRIAC switch imaginable. Yet it provides all of the advantages listed above.

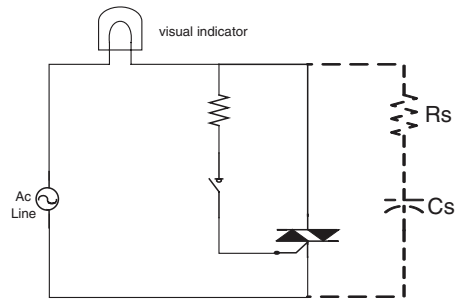

Graphic14_2

Figure 12. Simple Static Switch Application

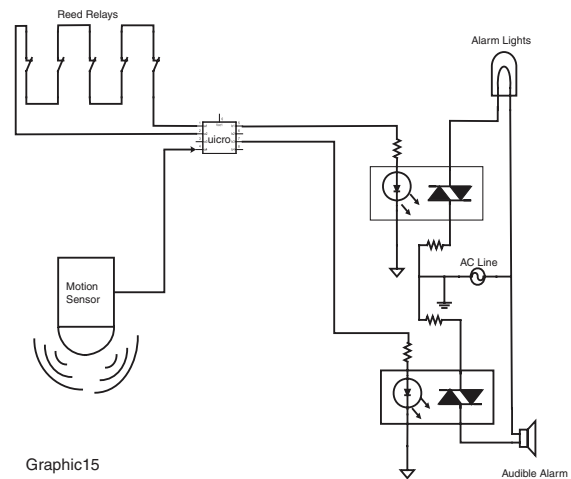

Graphic15

Figure 13. Alarm Switch Application

Vishay Semiconductors

Replacing the TRIAC with a phototriac would provide the further advantage of safety isolation from the high-voltage output to the triggering switch. This is of vital importance if the low-voltage triggering circuit is accessible to the operator or devices are susceptible to noise. This type of application refinement is illustrated in Figure 13.

TRIACs, as static switches, are commonly used on the output of power supplies as “crowbar” protection. This TRIAC solution is illustrated in Figure 14. Here the TRIAC is used as a DC latch rather than in its conventional role as an AC switch. It works like any other type of overvoltage sensing scheme. A comparator senses the output voltage and triggers an alarm based on some predetermined trip point. A crowbar circuit has the added feature of tying a power TRIAC across the output of the supply and having this TRIAC triggered by the output voltage comparator circuit. Consequently, when the TRIAC is triggered into its conduction mode by an overvoltage condition, it latches into a conduction mode, due to the fact that the TRIAC will not turn off until a zero current crossing turns off the TRIAC. Thus, the crowbar overvoltage protection scheme protects any output load from any possible overvoltage condition by forcing the output low by “shorting” the output.

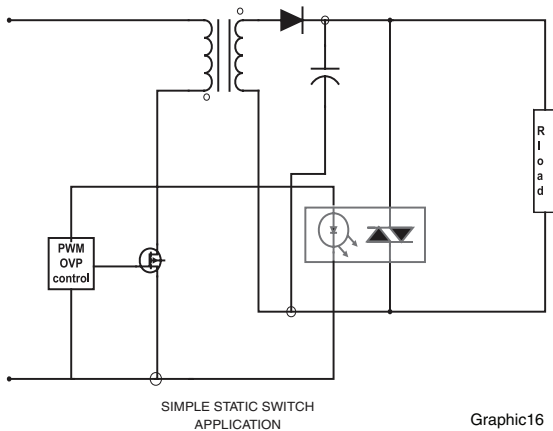

Figure 14. Simple Static Switch Application

An additional power supply application is the use of a TRIAC as an AC switch to bypass the inrush limiting element in a power supply. In most cases this function is accomplished by the use of a mechanical relay; however, a phototriac or phototriac/power-TRIAC combination can often perform this function with the added advantage of solid-state reliability, as illustrated in Figure 15.

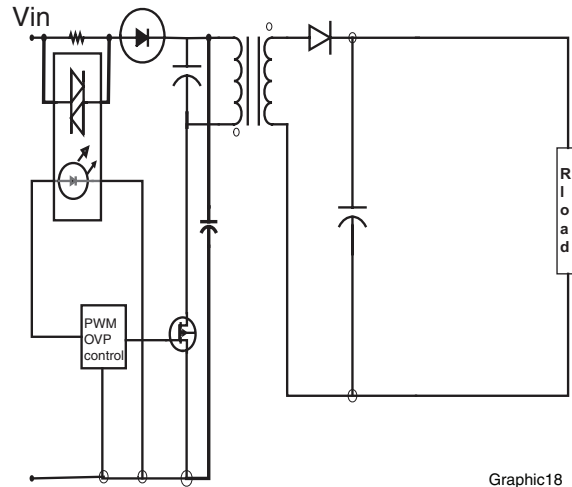

Figure 15. Inrush Limit Bypass Application

Phototriac Based Solid State Relays

Solid-State Relays (SSRs) were once the exclusive realm of thyristor devices, but since the advent of power MOSFETs this is no longer the case. Today thyristors still comprise a large share of the devices that are commonly referred to as SSRs. Many high-power industrial SSRs, known and “hockey pucks”, are actually optically isolated TRIACs. These can range from devices that have load current ratings of a few hundred milliamps to hundreds of amps. For strictly AC environments, thyristor devices still enjoy a wide acceptability in many commercial and industrial applications. They offer operation at high power ranges with acceptably low on-state voltage drops.



Figure 16. Commercial High-Power SSRs

Vishay offers an extremely broad range of Phototriac to drive power TRIACs. Vishay’s phototriacs provide designers with flexible and economic alternative to more expensive “hockey puck” solutions (Figure 16). Figures 17-a and 17-b illustrates alternative to using a commercial solution in a high-power AC switching application. Many “hockey pucks” employ lower-power phototriac drivers in their designs. If cost is a primary concern, this alternative can offer high-power performance for the price of an off-the-shelf power TRIAC and phototriac IC driver.

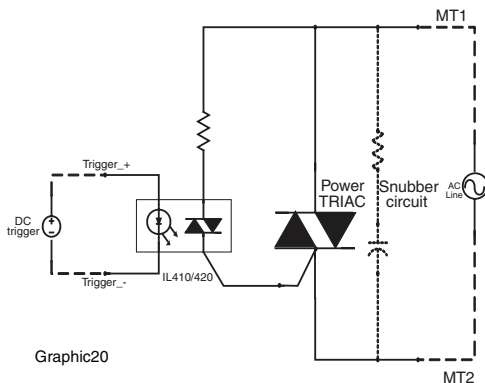

Figure 17-a. TRIAC Driver Basic SSR

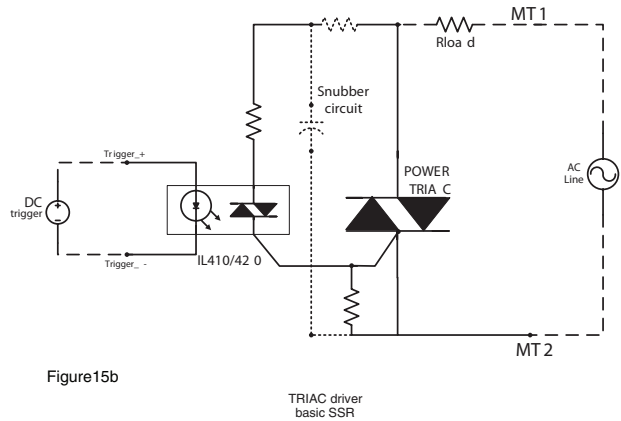

Figure 17-b. TRIAC Driver Basic SSR

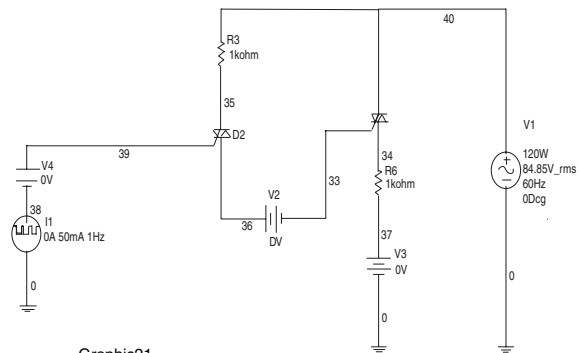

Figure 17-c. In depth TRIAC Driver Model

In applications where a phototriac works as a power TRIAC driver, commutating dV/dt is less of an issue when a narrow pulse is used to trigger the power TRIAC than when an phototriac is used to drive a load directly. This is because in the case of a driver circuit the phototriac immediately turns off when the main TRIAC turns on; therefore the driver phototriac has an entire half-cycle in which to discharge its gate charge. This concept is illustrated in Figure 18.

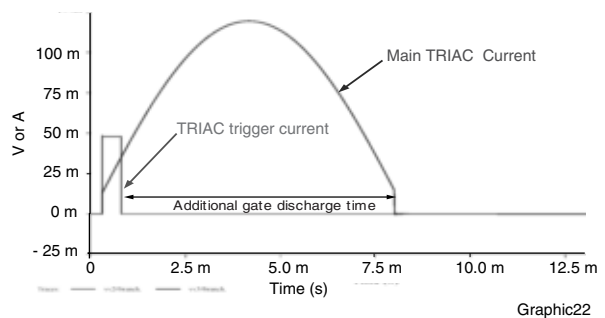

Figure 18. TRIAC Driver Waveforms

Vishay Semiconductors

Critical Design Parameters

The critical design parameters to be considered for phototriacs are its DC, AC, and thermal characteristics.

DC Characteristics

From a designer's point of view understanding the key parametric characteristics of an phototriac is very similar to understanding an ordinary TRIAC. The main difference rests with the way in which the trigger current is supplied to the TRIAC. Unlike a standard TRIAC, where the trigger current is supplied directly, the trigger current for an phototriac is supplied indirectly by means of a photocurrent generator on the detector side; however, the designer can treat this current just the same as the trigger current for any standard TRIAC. This has to be qualified with the caveat that when calculating the worst case I_{FT} , one has to go through a worst case analysis similar to that described in the beginning section of this document.

The next crucial parameters to be considered are V_{DRM} and $V_{D(RMS)}$. These parameters describe what is commonly referred to in the TRIAC world as the breakover voltage. In Vishay's data-sheets, these two parameters are referred to respectively as Off-State-Voltage and Repetitive Peak Off-State-Voltage. It describes the maximum voltage that can be placed across the anode-cathode terminals of an phototriac, without "turning on" the device. In some Thyristor devices, such as DIACs, this 'is' the normal operating mode; however, when it comes to phototriacs and photoSCRs, this maximum voltage value should never be exceeded to avoid permanent damage to the part.

In conjunction with the Off-State-Voltage and Repetitive Peak Off-State-Voltage, it is sometimes necessary to take into account the Off-State-Current $I_{D(RMS)}$. This parameter denotes the phototriac's leakage-current, or the current that the device will pass in its off-state. An occasion where this

may be critical is when an phototriac is being used as a "TRIACDRIVER", and driving a TRIAC with a particularly low trigger current. In its continuous operating region, it is also important to know what the expected voltage across the device will be, when the device is turned on. This parameter is referred to as the On-State Voltage or V_{TM} . This parameter in conjunction with the On-State-Current I_{TM} is most often used to determine the maximum operating point of the device at any particular ambient temperature.

Thyristors are latching devices, when used in DC mode. That is to say that, once triggered they will conduct even if the triggering signal is henceforth removed. These devices are turned off by lowering the current through the device to a very low value, close to zero. Exactly how much current through the TRIAC is required to keep it in conduction mode is referred to as holding-current or I_H .

Most of the important DC characteristics that must be considered when designing with phototriacs can be graphically measured using a standard curve tracer. This instrument will produce a set of curves such as the one in Figure 19.

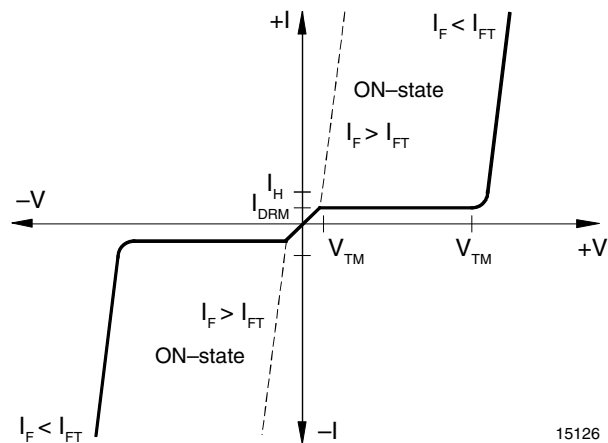
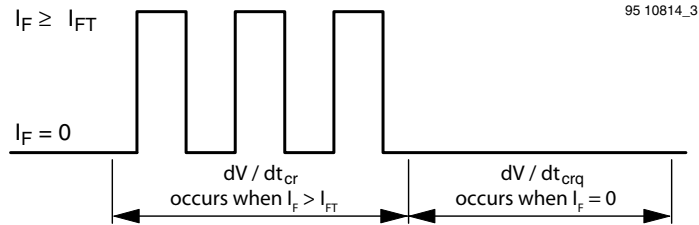

Figure 19. Characteristics curve of an phototriac

AC Characteristics

In addition to the DC characteristics that need to be considered when designing with phototriacs, there are some very important AC characteristics that need to be considered. One of the most important of these is the dV/dt of the output waveform. The Output dV/dt parameters can be divided into two separate categories, and which of these we consider depends on the state of I_F . If I_F is continuously off, dV/dt_{crq} (static dV/dt) becomes the parameter of interest. While if I_F is changing, dV/dt_{cr} (commutating dV/dt) is the parameter that should be examined. The differences between these two dV/dt parameters are graphically explained in Figure 20.



dv/dt_{cr} Highest value of the “rate of rise of off-state voltage” which does not cause any switching from the off-state to the on-state
 dv/dt_{crq} Highest value of the “rate of rise of commutating voltage” which does not switch on the device again, after the voltage has decreased to zero and the trigger current is switched from I_{FT} to zero

Figure 20. dv/dt_{cr} and dv/dt_{crq}

When using TRIACS, inductive loads present a problem because the voltage and current are not in phase with each other. Since the TRIAC turns off at zero current, it may be trying to turn off when the current is zero but the applied voltage is high. To a TRIAC, this appears like a sudden rise in applied voltage, which would turn on the TRIAC if the rate of rise exceeds the device commutating dv/dt_{cr} .

If and when the transient voltage disturbance on the AC line is higher than the rated static dv/dt of the TRIAC, the TRIAC will be triggered on. This is usually not a big problem because the TRIAC will turn off at the next zero crossing of the line voltage, and most loads are not noticeably affected by an occasional single half cycle of applied power. Thus whether or not dv/dt_{crq} is important depends on the user’s application.

In either case of output voltage dv/dt , it is important to note that Vishay has phototriacs available with the **highest dv/dt** ratings available in the industry. Some of these can go as high as 10000 V/ μ s. Having such high dv/dt ratings allows for the design of TRIAC circuits that can handle very rapidly changing output voltages without the need for snubber circuits. This inherent dv/dt immunity, reduces parts count, inefficiency, circuit size, and overall cost.

Getting an idea of how fast your load voltage changes is simple in the case of a “nice” sinusoidal output waveform. When the dv/dt waveform is a more complex function such as a transient produced by the “inductive kick-back” of a highly inductive load, a measurement is worth a thousand impressive calculations. In the simple case of a sinusoidal output waveform, the analysis would flow as follows:

$$V = V_{peak} \sin(\omega t)$$

$$dv/dt = V_{peak} * \omega * \cos(\omega t)$$

given $\rightarrow V_{peak} = \sqrt{2} * V_{rms}$

-
-
-

$$dv/dt = 8.89 * V_{rms} * f$$

where f = frequency.

For additional information on TRIAC AC characteristics, specifically TRIAC output dv/dt concerns and considerations refer to “TRIAC dv/dt Application Note”.

Phase Modulation Control

While zero-voltage crossing is desirable from an RF noise generation point of view, it is not possible for many AC switching applications. In general, when the switching time constants of the physical control phenomena involved are close to or less than the half cycle of the line voltage, zero-voltage switching is not effective because the control resolution is too “rough.” For example if one is trying to control a light-bulb’s output intensity, it is desirable to have continuous resolution over the entire range of operation. With zero-voltage switching, the smallest increment that could be achieved in terms of control resolution would be one half of the line frequency period. In the case of heater control, the time constant of the thermal phenomena to be controlled is so large that one half cycle of line voltage resolution would be adequate in most cases.

Applications that require a finer control resolution than is achievable with zero-voltage control can be met by using a technique known as phase modulation (PM) control. This technique requires the TRIAC to be fired anywhere along the line voltage conduction

angle, with the operating principle being that the conduction angle is varied to increase or reduce the resulting overall RMS voltage at the output, as illustrated in Figures 21-a and 21-b. The disadvantage of this technique is that there is an inherent increase in the level of RF that is generated. When fine resolution is required, however, this is a price that must be paid with greater effort being expended to achieve a low-EMI PCB layout, filtering, and, as a last resort, shielding.

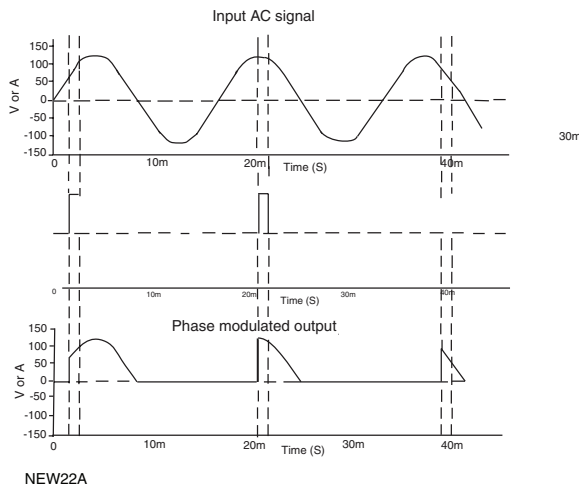

Figure 21-a. Phase Modulation Control

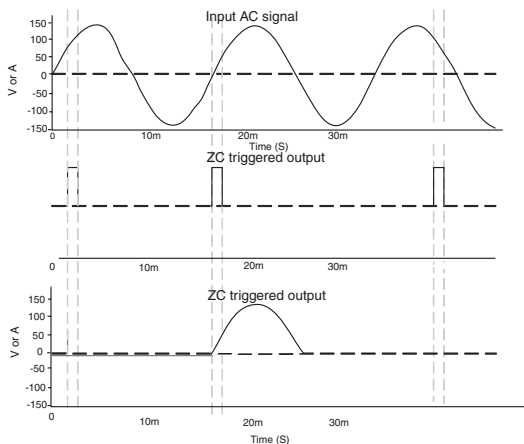

Figure 21-b. Zero-Crossing Modulation Control

All applications that require fine resolution control are good candidates for PM control and can utilize the NZC family of phototriacs. Good examples of applications requiring this type of solution would be lighting

dimmers, universal motor controls where continuous speed control is required, SCR-based voltage regulators, and SCR-based welders. In all these examples, zero-voltage crossing would result in too coarse a solution in terms of output voltage control. An excellent choice for the ZC application would be an IL420, because it has the superior performance of an IL410 ZC part but allows for NZC operation.

Thermal Design Parameters

The last set of parameters that should be considered are the thermal design parameters. Vishay phototriacs are designed to operate at power dissipation levels as high as 0.5 Watt. When one is dealing with a DIP-6 package, this is 'not' an insignificant amount of power. Moreover, TRIACs are often used in applications where the ambient temperature is other than standard room-temperature. Such is the case in many industrial and process control applications.

There are different approaches to take in the case of thermal design. The first is to go simply by a component derating number given in (Power/degrees). This is the simplest and safest approach to take. Manufacturers are very conservative when deriving this number. Consequently, if a designer follows this criteria it is unlikely that he will get in trouble. The second approach is very similar to this, but instead of a simple number, the designer follows a graph of allowable power vs. temperature similar to the one in Figure 22. Again, this is a very conservative approach and should allow for a very reliable design.

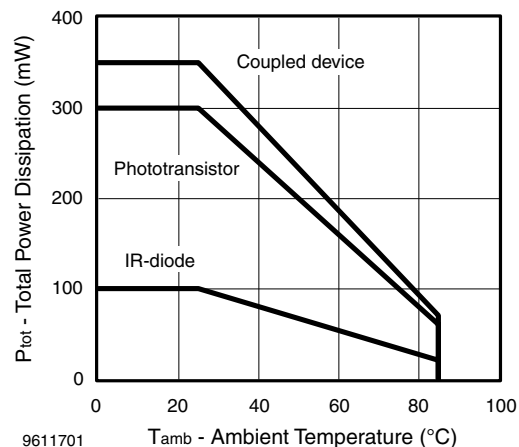

Figure 22. Allowable Dissipated Power

If the above two methods are not sufficient for the application, it is possible to calculate the thermal operating conditions, based on the given thermal impedance data, where such data is available.

The fundamental formula to remember when performing thermal resistance is the following:

$$\theta_j = \Delta T / \Delta P_{dis}$$

P_{dis} is in Watts while ΔT can either be in Celsius or Kelvin. Since relative and not absolute temperature quantities are involved Celsius or Kelvin can be used. If someone requires convincing, they should try it both ways. The result will be the same.

The previous method 'is' quite straight forward and simple, the complication comes in getting the appropriate θ_j .

One can have the following forms of θ_{jx} , θ_{jc} (junction to case), θ_{jb} (junction to board), θ_{jj} (junction to junction), as can be found in hybrid circuits such as optocouplers, and θ_{ja} (junction to ambient). As is the case for most low power IC manufacturers, Vishay usually gives the θ_{ja} values for most parts. In some occasions θ_{ja} values are given for the LED and Detector. In such cases, the conservative approach is to calculate both separately, and take the worst case. It is important to note that published junction temperatures are 'absolute' maximums. They should not be designed to or even approached if it all possible. It is an established fact that reliability and operating temperature are closely linked and inversely proportional when dealing with semiconductor devices. In other words, if you run it hot, a part may still be under guarantee when it fails, but it will not last as long as if it were running cooler; therefore, thermal margin is crucial to reliable designs.

Finally, the most accurate way of conducting thermal calculation is by using a thermal model. Hence, Vishay had conducted extensive studies to establish a thermal model to be used for calculating the thermal operation condition for its family of power products, phototriacs and optocouplers. For additional informa-

tion on thermal calculations please refer to "Thermal Design Application Note".

Sample Circuits:

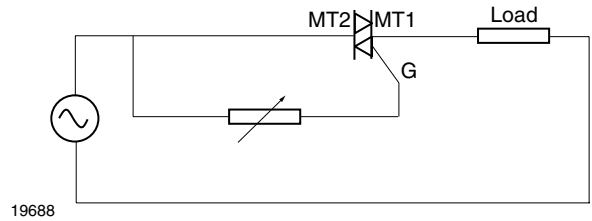

Figure 23. Phase-Shift controller

Figure 23, in spite of its apparent simplicity, forms the basis of a great deal of practical TRIAC circuits. It is sometimes referred to as a "phase-shift controller". If the input to the above circuit is a sinusoidal waveform, the output will be some "chopped up" fraction of that waveform. This allows for the efficient and economical control of the rms AC voltage. Some variant of this type of control is often used in commercial/consumer applications such as light-dimmers, and universal motors.

Vishay's phototriacs can handle currents in the range of 100's of mA. However, many TRIAC applications require current handling capability of several amps. In such applications, discrete phototriacs can not be used directly, but can be used in conjunction with standard high power TRIACs to yield simple, low part-count, cost effective solutions to higher power AC switching applications. In this type of application, phototriacs are used as "TRIAC drivers". In other words, they provide the gate current and isolation required to drive standard high power TRIACs, as seen in the drawing on the right-hand top of this page.

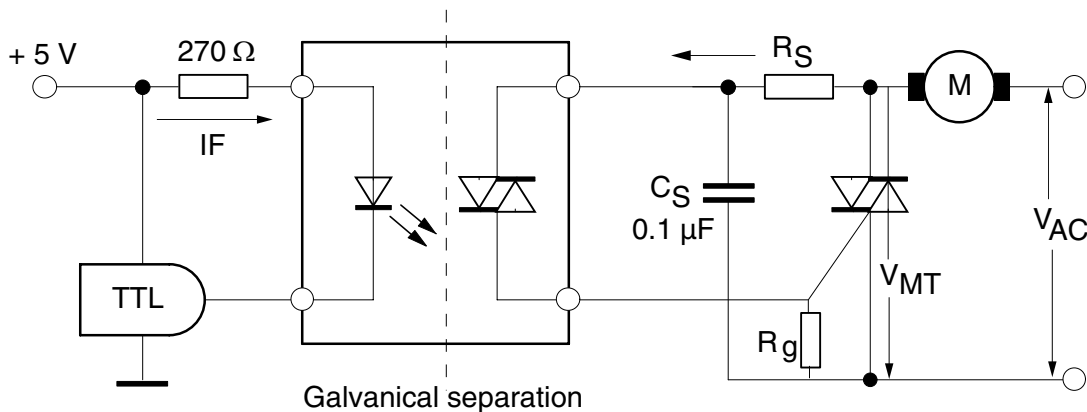

Figure 24. TRIAC driver example

Vishay Semiconductors

In addition to providing an example of an application where an phototriac is used as a TRIAC driver, the above circuit also illustrates the concept of using a snubber circuit and one of the main advantages of Vishay's phototriacs.

The circuit in Figure 24 is driving an electric motor, which under most circumstances is a highly inductive load. This in turn leads to unique difficulties in terms of output dV/dt . When inductive loads are switched rapidly they generate high transient spikes quantified by $V = L di/dt$. The L in the case of even small electric motors is comparatively large, thereby generating equivalently large values of dV/dt on the output. Such large skewing in output voltage could generate false triggering as described in previous sections.

There are two options to deal with this problem. The first is to use Vishay's high dV/dt (10000 V/ μ s) phototriacs, and call it victory, because the inherent high dV/dt immunity will solve the problem.

The second is to add a snubber similar to the one included in the circuit shown above.

The basic design process for arriving at the most advantageous snubber possible is as follows:

1. What is the highest tolerable dV/dt that a particular phototriac can withstand?
2. Use $dV/dt = V/(R_s * C_s)$ to come up with an appropriate RC combination

In addition to having the highest dV/dt specifications in the industry, Vishay optocouplers are also available with internal zero crossing features. This is to say that for the ZC phototriacs, they are designed such that they can be triggered only when the load voltage is nominally at zero volts. Incorporating this feature in various applications greatly decreases circuit complexity and reliability, by reducing the number of parts required to implement this functionality.

As the case for optocouplers in general, phototriacs are well suited for the current trend towards increasing embedded intelligence and microprocessor control. By allowing the designer to separate the "power-stage" from the controller/firmware portion of the system it allows for simpler and lower costs designs. This is true in industrial automation where microprocessor based systems control large numbers of widely varying AC and DC loads.

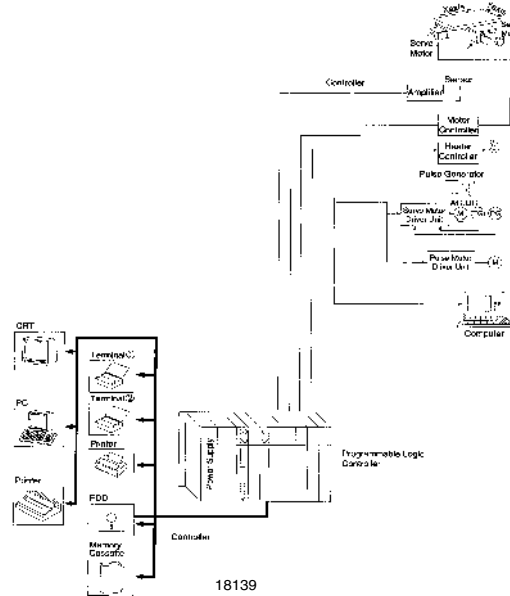

Figure 25. Industrial Programmable Logic Example

In addition to Industrial process controls, there is an increasing trend to the use of solid-state switches, to replace traditional EMRs (Electro Mechanical Relays) in the consumer appliance market. Solid-state switches such as TRIACs and SSRs offer highly reliable solutions that are well suited to the increasingly microcontroller dominated consumer market place.

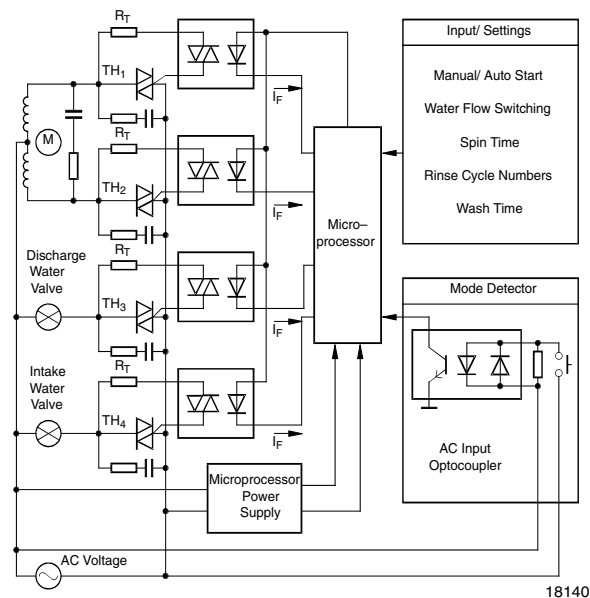

Figure 26. Consumer Appliance Example

Finally, it is important to emphasize that phototriacs are not by any means limited to the above applications. The possible uses for phototriacs are limited only by the designers imagination. Should there be

any questions regarding the efficacy of using these products to provide new and unique solutions, do not hesitate to contact VISHAY applications engineering for further support.

Microwave Oven with Grill

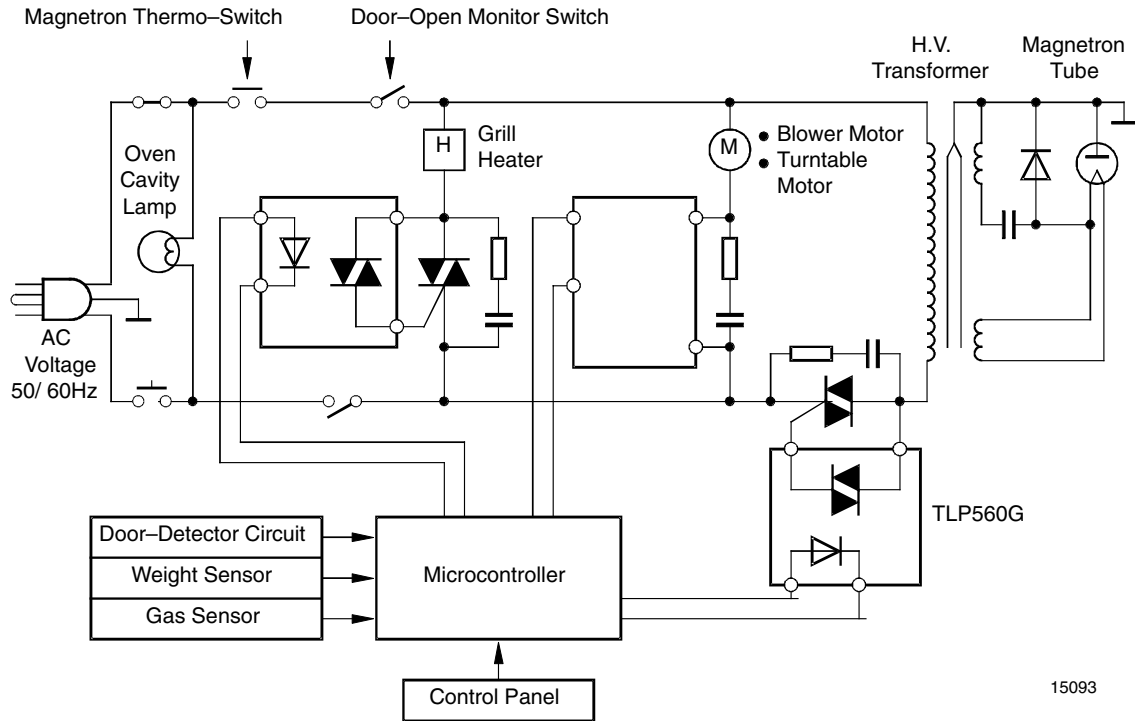

Figure 27. Microwave Oven with Grill Example

15093



Vishay Semiconductors

References:

Herman L. Stephen, Industrial Motor Control. Albany, NY: Delmar Publisher, 1998.

Malvino Albert Paul, Electronic Principles, NY, McGraw Hill, 1983.

Mazur Glen & Rockis Gary, Electrical Motor Controls,.Homewood Ill., American Technical Publishers Inc., 1997.

USEFUL WEB Links:

Vishay <http://www.vishay.com/optocouplers>

UL <http://www.ul.com/>

IEC <http://www.iec.ch/>

FIMCO http://www.sgsfimko.fi/index_en.html

BSI <http://www.bsi-global.com/index.xalter>

CSA <http://www.csa-international.org/default.asp?language=english>

VDE <http://www.vde.com/VDE/de/>